

**2040
SERIES**

SERVICE MANUAL

TABLE OF CONTENTS

INTRODUCTION

TEST PROCEDURES

INTRODUCTION

The 2040 Dual Disk System Service Kit will provide the Service Center means to isolate defective components or subassemblies by way of utilizing the internal diagnostics of the 2040, program diagnostics and trouble-shooting guides included on diskette and cassette.

Some of the procedures are redundant but each procedure performs different operations even though it seems to be the same procedure;

The service procedures have been broken into categories to enable you to do an overall check or test a particular area of the 2040 system. The procedure relating to the SA 390 drive exercises all areas including alignment capability. Alignment procedures have been deleted due to necessary special tools and training. Commodore will provide this training in designated locations and times. You will be notified of schedule.

We have also included in the 2040 Service Kit, a price list for SA 400.

1. Position the computer and 2040 near one another in an open work area.

2. Locate the power switch on each machine and place the rocker switch in the OFF position (the white dot on the switch not visible).

3.0 Plug the power cord into an AC outlet. Power on the 2040 System without connecting to the 2001. Check the three (3) LEDs located on the front panel. (fig. 1) They should turn on momentarily. If all the LEDs do not extinguish then a problem has developed in the system. The diagram below indicates possible location of the defective component.

LEDs	Possible Defective Component
----	-----
• • •	6532's, 6530, 6504
o • •	6332 at L1
• • o	6332 at H1

4.0 Power 2040 System OFF before replacing any components. After changing components and problems still exist, replace Digital Logic assembly.

5.0 Connect a PET to IEEE cable between the systems.

6.0 Apply power to the 2001 and note the power on message. Power on the 2040, the LEDs on the front panel should light momentarily.

7.0 PET DOS SUPPORT

7.0 Before you start testing the 2040 system, it's a good idea to load the PET DOS SUPPORT program into the 2001. The program is designed for easier accessibility to the commands of the 2040 system. See Appendix B for detail description of the use of PET DOS SUPPORT.

7.1 To load a program from mini-diskette:

7.1.1 Place the "2040 System Test" diskette in drive 0 of the 2040 system and close the door.

TYPE

LOAD"*,8 [RETURN]

Drive 0 on the 2040 system will initialize the diskette and load the first program on the diskette. Note the error LED on the front panel of the 2040. If an error occurs then some problem occurred. Power OFF the 2001 system then back on. Repeat this step. Be sure to remove diskette before turning power OFF.

7.1.2 If you are unsuccessful the second time to load the program from drive 0, try to load the program from drive 1. The procedure is as follows:

1. Insert 2040 Test mini-diskette into drive 1.

2. TYPE

OPEN 1,8,15,"I1" [RETURN]

This will initialize the mini-diskette on drive 1.

3. When the cursor returns to the screen

TYPE

LOAD"1: PET"*,8 [RETURN]

The program should now load in the 2001. If the error light turns on, you have isolated the defect to the Digital Logic or analog assembly. By trying to load the program from both drives eliminated drive failure. Proceed to step 7.2 for loading procedures from cassette tape.

4. TYPE

RUN [RETURN]

The screen will now display PET DOS SUPPORT. See Appendix B for detail description of the use of PET DOS SUPPORT.

5. To load the first test program use the following procedure:

TYPE

↑LOG* [RETURN]

The Logic Diagnostic program will be called from storage on the mini-diskette and be loaded into the 2001.

6. Proceed to 8.0 for operating instructions of the Logic Diagnostic test.

7.2 To load a program from cassette tape.

7.2.1 Connect the C2N unit to the tape interface connector on the 2001 or use the internal cassette unit.

7.2.2 Place the 2040 SYSTEM TEST/C tape in the cassette and rewind the tape.

7.2.3 Load the first program on the tape by depressing the "SHIFT" key and "RUN/STOP" key simultaneously. When the program finishes loading, the 2001 will display PET DOS SUPPORT program. See appendix B for detail description of the use of PET DOS SUPPORT.

7.2.4 Load the Logic Diagnostic program from cassette tape by depressing the "SHIFT" key and "RUN/STOP" key simultaneously.

The 2001 will display:

```
SEARCHING
FOUND LOGIC DIAGNOSTIC
LOADING
```

7.2.5 The Logic Diagnostic program will load from cassette tape and execute. The entire loading process should take approximately one minute.

8.0 LOGIC DIAGNOSTIC TEST

8.1 Follow the instructions that appear on the display of the 2001. If the logic components on the Digital board are in working order, the front panel LEDs will randomly blink. If a problem has been detected a slow distinct pattern will be present. Reference the chart on the screen of the 2001 to isolate defective component.

FAIL STATES OF DIAGNOSTICS

STATE	COMPONENTS-POSITION
• • •	6532-- E1, C1
• • o	6332-- K1
• o •	6332 - H1
• o o	2114 - C4 to F4 C5 to F5
o • •	6532 - E1, C1, Connector P1
o • o	6530 - K3 6504 - H3
o o •	6530 - K3

When the program detects an error condition, it will loop on the address where the error has occurred. The select line on the chip will toggle at a steady rate. In the case of a RAM failure, the select line will toggle the 1K blocks. Note, the block with the error condition and replace one of the two RAMs in the block.

8.2 If you are unable to isolate the failure replace the digital logic board.

8.3 Turn power off before replacing any components on the 2040 system.

8.4 Power the 2040 system back on.
LOADING

8.5 Depress "RUN/STOP" key on the 2001, then depress the "SHIFT" key and "CLEAR HOME" key simultaneously. The 2001 display will now be blank.

8.6 To restart the "LOGIC DIAGNOSTIC" program:

TYPE

RUN [RETURN]

8.7 When the program has been run for 15 minutes and no failures have occurred you can assume the Digital Logic board is O.K.

9.0 " READ/WRITE" TEST:

The Read/Write test allows you to verify the Read/Write heads of the drive. Gross alignment errors and the analog board are also checked.

9.1 load the READ/WRITE test program from:

a) mini-diskette

or

b) cassette

9.1.1 FROM MINI-DISKETTE

TYPE

↑READ* [RETURN]

NOTE: Be sure to initialize drive before trying to load a program.

9.2 FROM CASSETTE TAPE

TYPE

LOAD "READ/WRITE" [RETURN]

When the cursor returns to the screen:

TYPE

RUN [RETURN]

The 2001 screen will instruct you to:

9.3 Insert formatted mini-diskettes labeled "A" in both drives and close the drive doors.

NOTE: You may create an "A" mini-diskette by formatting a blank mini-diskette on a known good 2040 system.

9.4 The first part of this program initializes both drives and checks the stepper motors. Answer the question yes or no. If the answer is yes the program will continue to the next check. If the answer is no a malfunction has been detected. Possible failures are Drive Unit, Analog Assembly, Bad Media, or 6522.

To verify a drive failure, connect a good drive unit in place of the suspected drive. You do not have to remove the drive in question. Set the good drive on top of the suspected drive and connect it to the appropriate connectors. This procedure allows you to verify the drive without disassembly of the 2040.

9.5 The second part of the program actually reads a sector on each track. The left side of the display shows two numbers, 0 and 1. These are the drive numbers. The graph displays tracks that have been tested. A black square or squares indicates one of the following devices is bad. Replace in order.

1. Bad Media
2. Bad Analog
3. Bad Drive

NOTE: Remember to turn power off and remove diskettes before changing assemblies

9.6 To complete the "Read/Write" program, the screen will ask you to repeat the test or to format the mini-diskette. The formatting of the mini-diskette is the last procedure of the test.

Upon completion of this test you will have checked the validity of the Digital Logic assembly, Analog assembly and parts of the drives. You should be able to load programs from mini-diskettes at this time. If not, repeat previous tests or consult Commodore Customer Service.

10.0 2040 TEST/ADJUST

The "Test/Adjust" program was designed to allow the user to test the function of the 390 Drives for correct operation. The program also contains the software to allow a trained user to align the SA 390 drives in the 2040 system. The program is menu oriented which allows the user to test specific functions of the Drive or to run the chain of tests to insure proper operation. Reference Appendix A for detailed explanation of each section.

10.1 Load the "Test/Adjust" program from mini-diskette by inserting the 2040 Test Diskette into Drive 0.

TYPE

↑2040 TEST* [RETURN]

NOTE: Be sure to initialize the drive before attempting to load the program.

10.2 The "Test/Adjust" program is now displaying the first menu. For simplicity the program has been broken down into categories.

Procedure 1

SA 390 Test and Checkout is a step by step procedure through all the different tests performed on the disks;

Procedure 2

SA 390 Adjustment and Alignment. This procedure will allow you to do all mechanical adjustments pertaining to the drive.

NOTE: Special tools and training are necessary for Head Alignment and Carriage Limiter Adjustment. DO NOT proceed with these two adjustments unless you have been factory trained.

Procedure 3
2040 Drive Compatibility. This procedure will allow you to check the alignment compatibility between the drives. It will format a mini-diskette on one drive and attempt to read it on the other.

Procedure 4
SA 390 Test Menu. Allows the user to individually select a test for all known problems without running through all the tests. After the selected test is completed it is a good idea to do a complete test.

Procedure 5
SA 390 Adjustment Menu. Allows the user to do the individual adjustments without going through all the adjustment procedures.

NOTE: Special tools and training are needed for Head Alignment and Carriage Limiter adjustment. DO NOT proceed with these two adjustments unless you have been authorized by the factory.

11.0 FINAL SYSTEM TEST

The Final System Test performs an overall test of the system. This test is divided into two parts, First part being file handling, read and write to and from different tracks, and exercises the 390 drives. Second part checks for soft errors, (soft errors are errors that are corrected by firmware). This procedure will detect all soft errors and will print out on the screen how many soft errors have accrued for each track of the diskette

11.1 Insert the 2040 SYSTEM TEST Diskette into Drive 0 and initialize the diskette.

11.2 TYPE

↑FI* [RETURN]

11.3 You will be instructed to insert the two formatted "A" diskettes and press RETURN

11.4 The program will first execute a new command on Drive 0 then on Drive 1 to check the mechanical movement of the drives. After the mechanical test the program will go thru a sequence of reads and writes.

11.5 If the test fails, note the failure and return to the appropriate test procedure for finding the defective component. Continue to the next part of the test by pressing the "C" key

11.6 The screen will inform you to insert the 2040 SYSTEM TEST diskette into drive 0 and press RETURN

11.7 The program will now load the diagnostic code to check for soft errors. Asterisks will be written across the screen during the loading of the machine code.

11.8 Remove the 2040 SYSTEM TEST diskette and insert the "S" diskettes in both drives. Press RETURN when ready.

11.9 The "S" diskettes contain a worst case pattern that covers the entire diskette. This part of the program attempts to read the entire diskette without obtaining a soft error. If a soft error occurs, the quantity of the soft errors and the track number on which they occur will be printed on the screen. Two complete passes of each drive is necessary to complete the test.

11.10 If an error has occurred restart the test by pressing the "R" key and noting the error on the second pass. If the error still occurs verify that all modifications have been done on the 2040 SYSTEM and the head alignment is correct.

11.11 After the completion of all the tests the 2040 SYSTEM has been exercised to the known limits of the software.
drive.

NOTE: Special tools and training are necessary for Head Alignment and Carriage Limiter Adjustment. DO NOT proceed with these two adjustments unless you have been factory trained.

APPENDIX

ADJUSTMENT PROCEDURE	A
PET DOS SUPPORT	B
COMPONENT CROSS REFERENCE	C
SA 390 PARTS REFERENCE	D

**APPENDIX
A**

**ADJUSTMENT
PROCEDURES**

A.0 HEAD STEPPER TEST

This test insures free operation and correct motion of the head carriage and stepper motor. The test first moves the head out to track 0 and then it moves the head in to track 34. The final portion of the test moves the head in and out between track 34 and track 0. If the drive does not respond as outlined above, there are two probable causes.

1. Bad stepper motor (replace the drive).
2. Improper stepper control (check stepper control circuits. Possible bad 6522).

A.1 LED TEST

This test checks the LED on the drive specified. The tests are on, off, and blinking. If the LED does not respond properly then skip (use yes responses) to the blink portion and check the signals to the LED. Possible failures are:

1. Signal to LED (replace the drive).
2. No signal to LED (could be the analog board, cables or the 6532 (E1) replace the faulty part).

A.7 WRITE PROTECT SWITCH TEST

This test allows the user to check the function of the write protect switch on the disk drive. The drive's LED will be on for protected and off for not protected.

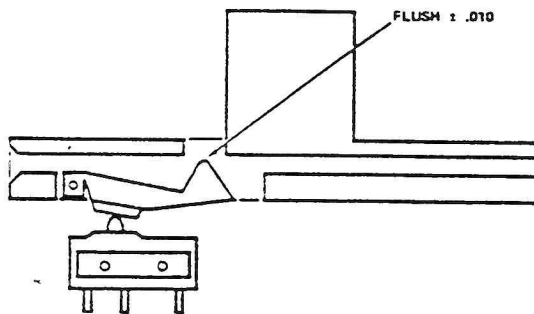

Failure of this test can be caused by the following:

1. Bad switch (replace drive).
2. Improperly adjusted switch.
3. Bad electronics (check 6530 UK3).

A.3 MOTOR SPEED ADJUSTMENT

Motor Test - will check motor operation and speed calibration. Adjust the motor speed pot with small flat blade screw driver until proper strobe pattern is stationary. Adjusting pot clockwise will move strobe counter-clockwise.

Turn the pot R-12 located on the motor control PCB until the dark lines on the spindle pulley appear motionless. For 60 HZ use the outside ring of lines. For the 50 HZ observe the inside ring. Reference Figure 4.

NOTE: This adjustment can be made only in an area where there is flourescent lighting.

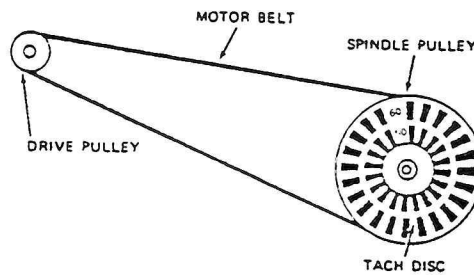

A.4 MOTOR SPEED TEST

This test checks the speed of the spindle motor to insure it is within tolerance. If the drive fails this test it should be replaced or if possible, realigned.

A.5 HEAD ALIGNMENT

NOTE: This adjustment is not normally required even on head replacement due to the pre-aligned head and carriage assembly, but if the stepper motor mounting screws are accidentally loosened, if parts damage has occurred or you are experiencing interchange problems use the following procedure to check and adjust the head alignment.

Remove and adjust drive 0 first. The drive may be removed by extracting the four (4) phillips screws from the bottom of the 2040 system and by removing the head and edge connectors from the analog board.

Once drive 0 is adjusted, replace drive 1 with it. The analog board can be removed from drive 1 by removing the connectors and extracting the two (2) phillips screws securing it in place. The analog board will slide off its mounts. Remove drive 1 by extracting the four (4) phillips screws holding the drive in place and sliding the drive out through the front panel.

Take a piece of cardboard (approximately 5" x 15" size) and lay it across the analog board extending to the right edge of the 2040 system. Locate the drive under test on the cardbaord and connect the head and edge connectors to the analog. Place the drive in a horizontal position (on its left side). Now you are ready to adjust the drive.

Use a dual trace scope and adjust the scope as follows:

Mode:	Add
Sweep:	20 MS
Volts/Div.:	50 MV
Probes:	3-X1
Trigger:	External

Connect channel 1 probe to TP4, channel 2 probe to TP3, on the analog. NOTE ANALOG PARTS LOCATION FOR LOCATION. Connect trigger probe to pin 9 on position UM5 of the digital board. Adjust the trigger level during the head alignment for a lobe pattern on the display.

Head alignment check with the scope should be performed in a horizontal position. Adjustments may be made from underneath or the drive may be put in a vertical position, then returned to a horizontal position for the check. Adjust stepper motor by loosening two clamp screws and slightly twisting the motor in the desired direction. Tighten with torque driver (#10). The initial head alignment should be made for maximum output and equal lobe sizes on scope display.

If either "hysteresis checks" result in unequal lobe sizes, then adjust to split the difference between the two lobes. If this occures, repeat the alignment check to assure that all positions result in appropriate lobe patterns. Appropriate patterns are lobes which are within 90% in size of each other. Note diagrams.

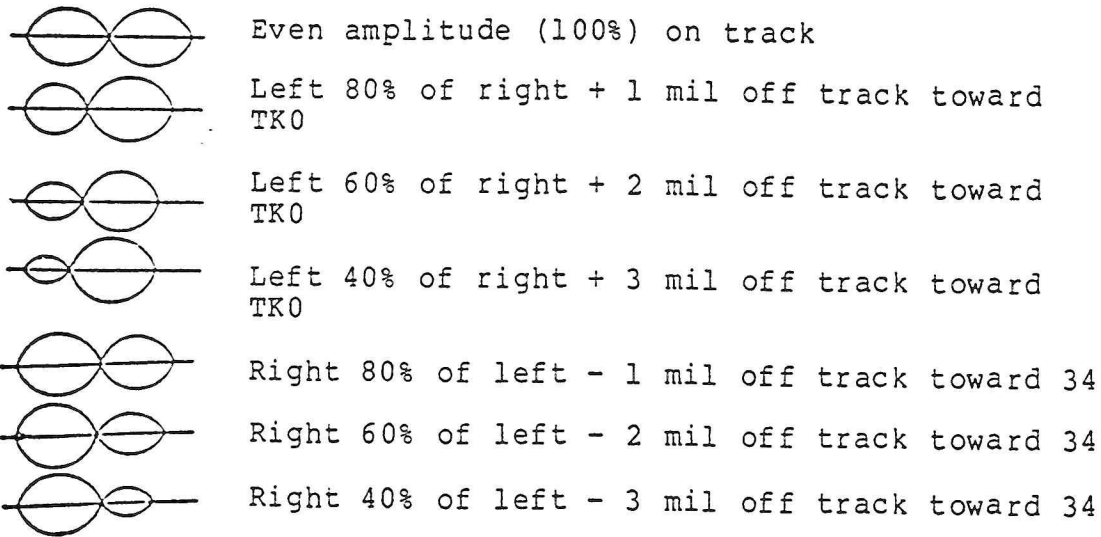

A.6 HEAD ALIGNMENT CHECK

This test is simply a validate of the system test diskette.

This diskette has a file that encompasses the entire disk. If any errors occur then there may be an alignment problem. Either replace the drive or align it.

NOTE: Insure your diskette is in good condition before using this test.

A.7 WRITE PROTECT SWITCH ADJUST

Use write-protect adjustment tool or diskette to adjust write-protect switch. Drive LED will detect protected--LED on and unprotected--LED off.

1. Loosen write protect switch screws and slightly tighten pivot screw (closest to spindle).
2. Insert tool until "shim stock" notch is even with opening in top of disk guide.
3. Raise switch with hex driver until switch closes (watch drive LED).
4. Tighten screws with torque driver (#11).
5. Push tool in all the way until it bottoms against the Platen stop (this will now line up the unprotect slot).
6. Remove write protect tool.
7. Close door.

**APPENDIX
B**

**PET DOS
SUPPORT PROGRAM**

DOS SUPPORT PROGRAM

The purpose of this program is to aid the PET 2001 User in operating the 2040 Dual Floppy Disk System. This instruction sheet has been written with the assumption that the reader has a working knowledge of the PET 2001 and the 2040.

NOTE: This program has been placed in the public domain. Please refer all comments and suggestions to the Editor.

The normal method with which the PET communicates with an IEEE Buss device is by the BASIC commands OPEN, PRINT, GET, INPUT and CLOSE. These statements are somewhat verbose in nature and therefore more prone to operator error. There is also the limitation that INPUT and GET cannot be used in direct mode due to shared buffer areas. These idiosyncrasies create a strained 2001/USER/2040 interface which has been greatly improved with the WEDGE 4.0 program.

WEDGE 4.0 may be loaded (saved) as if it were a normal BASIC program. Note should be made of the fact that the 2040 has a special load file name "*" which, if used immediately after power up (reset), executes the following:

1. Initializes Drive 0
2. Loads the first file on that drive

Thus if the command LOAD"*,8 is executed, and the WEDGE program is the first directory entry, it will be loaded. When the WEDGE program is executed, it relocates itself up into the highest available RAM memory locations, links into the CHRGET routine, and adjusts BASIC's top of memory pointer down. This technique uses about 350 bytes of the User's memory, but normal machine operations may proceed without having to reload the WEDGE program until such time that a system reset is performed.

The WEDGE program functions by capturing the data that the PET operating system passes to BASIC, before the interpreter has a chance to parse it. Thus we can look for the escape characters and process the command without the use or knowledge of the BASIC interpreter.

There are four escape characters that are recognized by the WEDGE program. They will be processed only when they are found in column one of an input line, otherwise a SYNTAX ERROR will occur.

ESCAPE CHARACTERS

- @ - Passes commands to the Disk.
- > - Passes commands to the Disk.
- / - LOAD's a program.
- - LOAD's and RUN's a program.

The greater than symbol (>), when used preceeding a 2040 Disk command, passes that command directly to the floppy disk system. See the following examples:

```
Thus:           >IO
is the same as: PRINT#15,"IO"
and:           >S0:FILE1
is equal to:   PRINT#15,"S0:FILE1"
```

As you can see, the > escape character is the directory list command. As you know, the directory of a minidisk can be loaded with a LOAD"\$0",8. This LOAD will destroy any program you might have in memory. To avoid the destruction of the current program, the WEDGE prints the directory on the screen.

```
>$0
```

Means - Display the entire directory of Drive 0

```
>$1:Q*
```

Means - Display the directory entries of all files on Drive 1 that have names starting with the letter Q.

The third function of the > escape character is the error channel interrogation feature. The error channel is read by typing a > followed immediately by a RETURN. This is equivalent to the following program segment:

```
10 OPEN 15,8,15
20 INPUT#15,ER,MSG$,DRV,SEC
30 ?ER","MSG$","DRV","SEC
```

The LOAD / and LOAD-RUN escape characters operate the same as their BASIC counterparts only with a simplified syntax as follows:

```
/WUMPUS
```

- The above command will load the program file WUMPUS. Both drives will be searched if required.

```
↑1:COPY DISK FILES
```

- This command will load the program COPY DISK FILES from Drive 1 (if it is there) and execute it.

```
5 SYS2221
10 PRINT""TAB(11)"$$$$$$$$$$$$$$$$"
20 PRINTTAB(11)" PET DOS SUPPORT "
30 PRINTTAB(14)"NOW LOADED
40 PRINTTAB(9)"  COMMANDS FOLLOWING"
50 PRINTTAB(7)"A > OR @  IN COLUMN 1 WILL"
60 PRINTTAB(9)"BE PASSED TO THE DISK."
90 PRINTTAB(7)"CMD      DESCRIPTION"
140 PRINTTAB(7)"$      DIRECTORY BOTH DRIVES
150 PRINTTAB(7)"$0     DIRECTORY DRIVE 0
160 PRINTTAB(7)"$1     DIRECTORY DRIVE 1"
180 PRINTTAB(7)"  ALL 2040 COMMANDS MAY BE
190 PRINTTAB(7)"ENTERED AS IF THEY WERE IN
200 PRINTTAB(7)"A PRINT# STATEMENT.
220 PRINTTAB(11)"SPECIAL COMMANDS
230 PRINTTAB(7)"/      LOAD A PROGRAM
240 PRINTTAB(7)"^      RUN A PROGRAM
250 PRINT"  SPECIAL COMMANDS START IN COL 1 AND
260 PRINT"ARE FOLLOWED BY A 2040 FILENAME.
270 NEW
EADY.
```

**APPENDIX
C**

**COMPONENT
CROSS REFERENCE**

2040 DIGITAL LOGIC ASSEMBLY PARTS CROSS REFERENCE

<u>REF. DES.</u>	<u>DESCRIPTION</u>	<u>PART#</u>	<u>DEALER PRICE</u>
C-1-C6, C8-C18, C21 C23-C29	.1 MF 50V	900020-01	.23
C31, C33, C35-C46	.1 MF 50V	900020-01	.23
C7	100 PF 50V	900010-17	.05
C19, C22	10 MF 20V	900402-09	.48
C20	.01MF 50V	900010-38	.05
C30, C32	10 MF 25V	900100-01	.10
C34	47 MF 16V5	900100-33	.33
CR1-CR6	1N5402	900753-01	.28
CR7-CR9	1N4001	900750-01	.11
P1	IEEE Conn. Right Angle	903206-01	5.85
P2	Header, .1 Spacing, 20 Pin	9033H-01	1.60
P3	Header, .156 Spacing, 5 Pin	903302-02	.13
P4	Header, .156 Spacing, 3 Pin	903302-13	.09
P4	Header, .156 Spacing, 6 Pin	903302-06	.14
P5	Header; .1 Spacing, 2 Pin	903307-12	.08
R1, R2, R12-R14	470 ohm, 1/4 W 5%	901550-58	.05
R3, R4	5.1 K ohms 1/4 W, 5%	901550-03	.05
R5, R6	2.4 K ohms 1/4 W, 5%	901550-85	.05
R7, R15, R16	2 K ohms, 1/4 W, 5%	901550-53	.05
R8	10 K ohms, 1/4 W, 5%	901550-20	.05
R9	100 K ohms, 1/4 W, 5%	901550-07	.05
UA1, UE6, UL2	74 LS 04	901521-02	.34
UA3, UB3	74 LS 42	901521-17	.85
UA4	7414	901522-19	.95
UA6	74 04	901525-01	.45
UB1, UB2, UD2	MC 3446	901524-01	2.47
UB4, UH6, UJ2	74 LS 00	901521-01	.32
UB6, UC6, UD6	74 LS 193	901521-26	1.15
UC1, UE1	6532 PIA	901458-01	10.50
UC3, UD3, UE3, UF3	74 LS 157	901521-11	.75
UJ5, UK5, UL5	74 LS 157	901521-11	.75
UC4, UD4, UE4, UF4	6114 RAM	901453-02	12.00
UC5, UD5, UE5, UF5	6114 RAM	901453-02	12.00
UF6, UH2	74 LS 02	901521-21	.48
UH1	6332-21, ROM	901468-07	20.00
UH3	6504 MPU	901455-01	10.00
UH5	74190	901522-16	1.18
UJ6, UN2	7406	901522-06	.36
UK3	6530 PIA	901466-02	14.00
UK6	6316 ROM	901467-01	20.00
UL1	6332-20 ROM	901468-06	20.00
UM2	LM555	901523-01	.45
UM3	6522 VIA	901437-01	12.00
UM5	74 LS 133	901521-15	.85
UM6, UN6	74 LS 165	901521-12	1.55
UN1	6502 MPU	901435-01	11.25

<u>REF. DES.</u>	<u>DESCRIPTION</u>	<u>PART #</u>	<u>PRICE</u>
UN5, UP5	74 LS 164	901521-28	1.23
VR1, VR2	7812 +12V 1.5A REG	901528-04	2.25
VR3	LM 323 +5 3A REG	901528-01	7.00
Y1	16 MHZ Crystal	900557 -01	1.40
	28 PIN I.C. Socket	904150 -05	.50
	24 PIN I.C. Socket	904150 -04	.35
	40 PIN I.C. Socket	904150 -06	.60

2040 ANALOG ASSEMBLY PARTS REFERENCE

<u>REF. NUMBER</u>	<u>DESCRIPTION</u>	<u>PART NUMBERS</u>	<u>DEALER PRICE</u>
C1,C2	4.7NF 25V Elect.	900101-07	\$.16
C3,C4,C10,C11,C14	.1MF 50V Cerm	900020-01	.23
C5,C15	300PF 500V Mica	900050-16	.45
C6,C7	750PF 300V Mica	900050-15	.83
C8	.033MF 50V Cerm	900020-03	.54
C9	10MF 20V Tant	900402-09	.48
C12	4700PF 200V Mica	900050-17	.53
C13	1.6MF 15V Tant	900105-01	1.20
C16	680PF 300V Mica	900050-01	.79
C17,C18	.01MF 50V Cerm	900010-38	.06
CR1-CR16	IN4003 Diode	900750-03	.11
CR17-CR26	IN4148 Diode	900850-01	.05
L1	100MH RF Choke	901301-01	2.30
L2,L5	150MH RF Choke	901301-02	1.30
L3,L4	680MH RF Choke	901301-03	1.18
P6	5 Pin Header (Power)	903302-02	.40
P7	20 Pin Header	903311-01	1.60
P9,P10	4 Pin Header (Read/Write Head)	903315-01	.98
Q1,Q2,Q5,Q6	2N4403	902704-010	.18
Q3,Q4,Q7-Q10	2N4401	902652-01	.15
R1-R4,R27	1K ohm $\frac{1}{4}$ W	901550-01	.05
R5-R12	680 ohm $\frac{1}{4}$ W	901550-31	.05
R13,R19,R20,R28, R31,R38	20K ohm $\frac{1}{4}$ W	901550-92	.05
R14,R23,R47	2K ohm $\frac{1}{4}$ W	901550-53	.05
R15	272 ohm $\frac{1}{4}$ W 1%	901751-10	.17
R16	909 ohm $\frac{1}{4}$ W 1%	901751-13	.17
R17	750 ohm $\frac{1}{4}$ W 1%	901751-09	.17
R18,R25	2.26K ohm $\frac{1}{4}$ W 1%	901751-14	.17
R21	300 ohm $\frac{1}{4}$ W	901550-70	.05
R22	100 ohm $\frac{1}{4}$ W	901550-49	.05
R24	604 ohm $\frac{1}{4}$ W 1%	901751-11	.17
R26	510 ohm $\frac{1}{4}$ W	901550-38	.05
R30,R37	845 ohm $\frac{1}{4}$ W 1%	901751-12	.17
R32,R40	3K ohm $\frac{1}{4}$ W	901550-33	.05
R33,R41-R45	9.09K ohm $\frac{1}{4}$ W 1%	901751-15	.17
R36	75 Ω ohm $\frac{1}{4}$ W	901550-45	.05
R39	68 Ω ohm $\frac{1}{4}$ W	901550-94	.05
R46	75K ohm $\frac{1}{4}$ W	901550-86	.05
RP1,RP2	330 ohm Resistor Pack	902422-01	.75
RP3	680 ohm Resistor Pack	902422-02	.75
UA2	9602 One Shot	901510-01	.80
UA3	7486 Exclusiv or Gate	901522-18	.50
UA4	LM 311 Voltage Comparator	901523-04	.90
UA5	LM 592 OP-AMP	901523-08	2.35
UB1,UD1	7406 Hex Inv. Buffer	901522-06	.40
UB2,UC1	74LS04 Hex Inv.	901521-02	.35
UB3	74LS74 Flip-Flop	901521-06	.50
UC3	Q2T2905 Transistor Pack	902551-01	1.96
UC5	Q2T2222 Transistor Pack	902550-01	1.96

**APPENDIX
D**

**SA 390
PARTS REFERENCE**

SPARE PARTS PRICE LIST FOR SHUGART 390 DRIVE

<u>REF. NUMBER</u>	<u>PART NUMBER</u>	<u>DESCRIPTION</u>	<u>PRICE</u>
47	10166-0	Screw 2/56X.500	.50
19,16,10,4	10186-0	SCW#6-32X.19 T10159	.50
39,12,29	10187-0	SCW#6-32X.25 T10159	.50
50	10189-0	SCW BH 6-32X.375 T1	.50
37	10191-0	SCW#6-32X.50 T10159	.50
43	*10804-0	Bearing, Ball	4.50
14	*10805-0	Bearing, Ball	5.00
6	11305-0	Ring Retaining	.50
58	11312-0	Fastener, LED	1.00
54	11900-0	Screw 6/32X.250	.50
56	12501-0	Lock Wahser #6 T12502	.50
57	15663-0	Tab, Fasion	.50
59	15915-0	LED, Red	1.50
45	17212-0	Switch Write Protect	3.00
35	25063-0	Drive Mtr Speed	
		Control AM	22.00
24	54003-1	Cam-Actuator	.50
17	54006-0	Rod, Guide	1.50
13	*54032-0	Spindle-Machined	27.00
31	54038-0	Plate Trk 0	1.00
34	54047-0	Drive Motor	28.50
41	54048-0	Belt, Drive	5.00
25	54055-0	Carriage Head ASM	91.50
5	54057-0	Stop, Diskette	.50
46	54062-0	Plate Nut	.50
9	54066-1	Hub Clamp ASM	6.50
33	54067-0	Drive Motor ASM	45.00
38	*54068-0	Step Motor ASM	27.00
2	54070-0	Hub Frame ASM	39.50
3	54073-0	Door Hinge ASM	2.00
53	54077-2	Cover, Front	2.50
1,520	54078-0	Keeper, Guide Rod	.50
60	*54089-0	Guide Disk ASM	
		Right Side	1.50
61	*54090-0	Guide Disk ASM	
		Left Side	1.50
44	*54097-0	Spacer, Long	1.00
18	54099-0	Clamp, Guide Rod	.50
49	54125-0	Platen, Machined	
		Complete	1.50
7	54131-0	Collar Hub	.50
8	54132-1	Spring, Clamp	.50
42	*54138-0	Pulley ASM	22.00
26	54145-0	Load Button ASM	1.50
1	320817-01	Analog Board	45.00

* Not Field Replaceable

